

Bid Document

Bid Details	
Bid End Date/Time	27-09-2022 18:00:00
Bid Opening Date/Time	27-09-2022 18:30:00
Bid Offer Validity (From End Date)	60 (Days)
Ministry/State Name	Pmo
Department Name	Department Of Atomic Energy
Organisation Name	Iter India Ipr
Office Name	literindia Ipr Blocka Sangath Skyz Bhatmote
Item Category	Goods Transport Services - Packaging
Contract Period	3 Month(s)
MSE Exemption for Years of Experience and Turnover	No
Startup Exemption for Years of Experience and Turnover	No
Bid to RA enabled	No
Time allowed for Technical Clarifications during technical evaluation	5 Days
Evaluation Method	Total value wise evaluation

EMD Detail

Required	No
----------	----

ePBG Detail

Required	No
----------	----

Splitting

Bid splitting not applied.

MSE Purchase Preference

MSE Purchase Preference	Yes
-------------------------	-----

1. Purchase preference to Micro and Small Enterprises (MSEs): Purchase preference will be given to MSEs as defined in Public Procurement Policy for Micro and Small Enterprises (MSEs) Order, 2012 dated 23.03.2012 issued by Ministry of Micro, Small and Medium Enterprises and its subsequent Orders/Notifications issued by concerned Ministry. If the bidder wants to avail the Purchase preference for services, the bidder must be the Service provider of the offered Service. Relevant documentary evidence in this regard shall be uploaded along with the bid in respect of the offered service. If L-1 is not an MSE and MSE Service Provider (s) has/have quoted price within L-1+ 15% of margin of purchase preference /price band defined in relevant policy, then 100% order quantity will be awarded to such MSE bidder subject to acceptance of L1 bid price.

2. Estimated Bid Value indicated above is being declared solely for the purpose of guidance on EMD amount and for determining the Eligibility Criteria related to Turn Over, Past Performance and Project / Past Experience etc. This has no relevance or bearing on the price to be quoted by the bidders and is also not going to have any impact on bid participation. Also this is not going to be used as a criteria in determining reasonableness of quoted prices which would be determined by the buyer based on its own assessment of reasonableness and based on competitive prices received in Bid / RA process.

Additional Qualification/Data Required

Scope of Work:[1662463097.pdf](#)

Dimensions of Goods packing to be Packaged:[1662111587.pdf](#)

Goods Transport Services - Packaging (1)

Technical Specifications

Specification	Values
Core	
Goods(product) in standard packages	No
Type of Shipping	International from one country to another country
Mode of Shipping	Sea Transportation
Type of Cargo	Industrial/ Warehouse
Packaging Material provisioning	Provided by Service Provider
Types of packaging material	plywood packaging
Types of corrosion preventive packaging	Not Applicable
Type of Load secured packaging	Not Applicable
Type of Long term packaging	Not Applicable
Addon(s)	
Dismantling (for machinery, household items like bed)	No
Civil Work	No
Additional Details	
Dimensions for the Cargo Package (Length * breadth * Height)in mm	1800*1250*2700
Weight of the Cargo Package in Kg	1300

Additional Specification Documents

Consignees/Reporting Officer

S.No.	Consignee/Reporting Officer	Address	Total number of Standardized Packages/ Total volume of goods in cubic feet	Additional Requirement
1	Mayurkumar Navinchandra Patel	380005,ITER-INDIA, IPR, BLOCK-A, SANGATH SKYZ, BHAT-MOTERA ROAD, KOTESHWAR, AHMEDABAD-380005, GUJARAT, INDIA	1	N/A

Buyer Added Bid Specific Terms and Conditions

1. Generic

Actual delivery (and Installation & Commissioning (if covered in scope of supply)) is to be done at following address ITER-India DNB Lab, Institute for Plasma Research, Nr. Mother Dairy Bhat Village Gandhinagar - 382428 (Gujarat, India).

2. Generic

1. The Seller shall not assign the Contract in whole or part without obtaining the prior written consent of buyer.
2. The Seller shall not sub-contract the Contract in whole or part to any entity without obtaining the prior written consent of buyer.
3. The Seller shall, notwithstanding the consent and assignment/sub-contract, remain jointly and severally liable and responsible to buyer together with the assignee/ sub-contractor, for and in respect of the due performance of the Contract and the Sellers obligations there under.

3. Generic

While generating invoice in GeM portal, the seller must upload scanned copy of GST invoice and the screenshot of GST portal confirming payment of GST.

4. Buyer Added Bid Specific ATC

Buyer Added text based ATC clauses

1. Details of Scope of Work , Technical Specification and Terms & Conditions for packaging of Beam Source Frame for transportation from ITER India Laboratory to PVA Germany are given in Annexure-A. To sign & stamp on each page of Annexure-A and to attach with the bid. This will be considered as an acceptance of bidder on Annexure-A by the bidder.
2. List of document to be attached in the Bid.
 - (i) MSME Udyam Registration
 - (ii) Signed Annexure-A.
 - (iii) Appendix-3 & Appendix-4(site visit)

Disclaimer

The additional terms and conditions have been incorporated by the Buyer after approval of the Competent Authority in Buyer Organization. Buyer organization is solely responsible for the impact of these clauses on the bidding process, its outcome, and consequences thereof including any eccentricity/restriction arising in the bidding process due to these ATCs and due to modification of technical specifications and/or terms and conditions governing the bid. Any clause incorporated by the Buyer such as demanding Tender Sample, incorporating any clause against the MSME policy and Preference to make in India Policy, mandating any Brand names or Foreign Certification, changing the default time period for Acceptance of material or payment timeline governed by OM of Department of Expenditure shall be null and void and would not be considered part of bid. Further any reference of conditions published on any external site or reference to external documents/clauses shall also be null and void. If any seller has any objection/grievance against these additional clauses or otherwise on any aspect of this bid, they can raise their representation against the same by using the Representation window provided in the bid details field in Seller dashboard after logging in as a seller within 4 days of bid publication on GeM. Buyer is duty bound to reply to all such representations and would not be allowed to open bids if he fails to reply to such representations. Also, GeM does not permit collection of Tender fee / Auction fee in case of Bids / Forward Auction as the case may be. Any stipulation by the Buyer seeking payment of Tender Fee / Auction fee through ATC clauses would be treated as null and void.

This Bid is governed by the [General Terms and Conditions](#), conditions stipulated in Bid and [Service Level Agreement](#) specific to this Service as provided in the Marketplace. However in case if any condition specified in General Terms and Conditions is contradicted by the conditions stipulated in Service Level Agreement, then it will over ride the conditions in the General Terms and Conditions.

In terms of GeM GTC clause 26 regarding Restrictions on procurement from a bidder of a country which shares a land border with India, any bidder from a country which shares a land border with India will be eligible to bid in this tender only if the bidder is registered with the Competent Authority. While participating in bid, Bidder has to undertake compliance of this and any false declaration and non-compliance of this would be a ground for immediate termination of the contract and further legal action in accordance with the laws.

---Thank You---

Annexure-A

Scope of Work , Technical Specification and Terms & Conditions for packaging of Beam Source Frame for transportation from ITER India Laboratory to PVA Germany

1. The boxes shall be non-stackable type and packaged for export worthy Packaging.
2. Desired packaging criterion: Wooden box with (pinewood) base frame (takes main load and keeps component in place) and reinforcement planks (pinewood) along edges/sides with plywood side walls of adequate thickness. At least one wooden cross plank is to be provided on top between side walls for additional rigidity. Material should be heat treated type with relevant ISPM 15 certification (to be provided by bidder). Adequate material thickness considered for each box to be justified by bidder (e.g. based on their experience/code calculation/etc.). For size of item to be packed, refer appendix 1. A separate assurance certificate concerning adequate material thickness and quality is to be signed and submitted by bidder during completion and handover of packaging (refer Appendix 2).
3. Detailed fumigation certificate to be provided by bidder.
4. The side panels of the box must be screwed type from side for easy access or dismounting when required.
5. Internally, the components inside the boxes should be wrapped in VCI bag (plastic type).
6. Desiccant powder bag (adequate as per the closed volume involved) should be provided inside the wrapping in each box, as applicable.
7. Polyester cord straps should be used for fastening of loose materials, support stand, etc. with base to prevent internal movement during transportation.
8. For handling during loading/unloading and thereafter, for access (of belt/chain/ pallet/ forklift/cranes) at base, adequate gap (a minimum of 4 inch or more) should be present in the wooden crates.
9. Procurement and mounting of (4 Nos.) the shock detectors on the boxes are in the scope of the vendor/packers.
10. The following markings are to be provided by the packer:
 - 'Handle with care', 'this side up' and 'protect from rain'.
 - Marking for chain sling/sling at wooden base.
 - Position of CG (center of gravity) on wooden box side walls.

Please Note:

- The concerned party shall carry out the packaging works under their own supervision at ITER
- India Lab (Address: ITER India DNB lab, Institute for Plasma Research, Bhat Village, Near Indira Bridge, Gandhinagar-382428, Gujarat – INDIA. For this actual site visit before submission of quotation is preferable. For this, intimation is to be provided at least 2 working days prior to visit. Contact person from the Purchaser's end is Mr. Ashish Yadav (Email: ashish.yadav@iterindia.in & Contact No. +9179 2326 9861) The following form needs to be filled and submitted by the vendor (refer Appendix 3). At the time of bid submission, signed site visit certificate (refer Appendix 4) is also to be attached.
- For box, the weight of the packaging material being used is to be provided for the purpose of calculation of gross weight.
- Pallets, trolleys and overhead crane are available at site. Besides this, if some other moving tool is required, then the bidder is supposed to arrange it on their own.
- Any other additional point or requirement (not covered in the section above) may be (recommended/specifically asked/ proposed) by the bidder.

Third party Liability:

The Service Provider will take all possible precautions to avoid damage to the equipments / systems / accessories during onsite support service at Purchaser's site. Service Provider shall also take insurance covering third party liability for the personnel deployed at Purchaser's site against all risks, such as injuries, loss of life etc. Service Provider will be fully responsible, liable and accountable for payment of compensation in the event of loss or damage to Purchaser's property and/or injury or loss of life to Purchaser's personnel during the course of onsite service support as a result of fault/s attributable to the Service Provider. Service Provider will be fully responsible, liable and accountable for such damages/losses and payment of appropriate compensation. Service Provider will relieve the Purchaser from all the liabilities under this clause.

Safety Requirement

The Service Provider shall take all necessary precautions to ensure safety of labourers deployed for the said work and arrange to provide prompt medical assistance if required. Service Provider should keep the fully equipped first aid box handy at the site. The purchaser is not in any case responsible for any type of accident and or incident during the execution of works and it will be

the total responsibility of the Service Provider. The Service Provider shall make his own arrangement for the security of his personnel employed for this job, materials, plants and equipment's etc. The Service Provider shall note that this work has to be carried out inside Institute's campus, hence special care shall be taken at the time of execution of the work. The Service Provider shall comply with the safety manual of the purchaser. Wherever site activities like installation, erection, commissioning and site acceptance testing are involved, the Service Provider must follow the IPR Safety Protocol which are available on ITER-India website under link: https://www.iterindia.org/display_file_grid.php# during execution of the work. The Service Provider shall give strict instructions to his personnel involved in the work, not to damage any equipment, fixtures, furniture and /or any items of the purchaser lying inside the building. The Service Provider is fully responsible to clean the floor, paint, fixtures etc., after the completion of the work / at the time of execution of the work. He should also note that after completion of the work he shall dispose or stack the debris outside / inside of the campus as directed by Purchaser.

Bidder Signature		
Name of the signatory & Title	Name	Title
Bidder's Official seal		
Place & Date	Place	DD-MM-YYYY

Appendix – 1: Item Description

Beam Source Frame Structure

Dimension of the item ~ L X B X H (in mm): ~1800 X 1250 X 2700

Weight of the Package: 1300 Kgs (Approx.)

Type of the Package: Stainless Steel frame structure

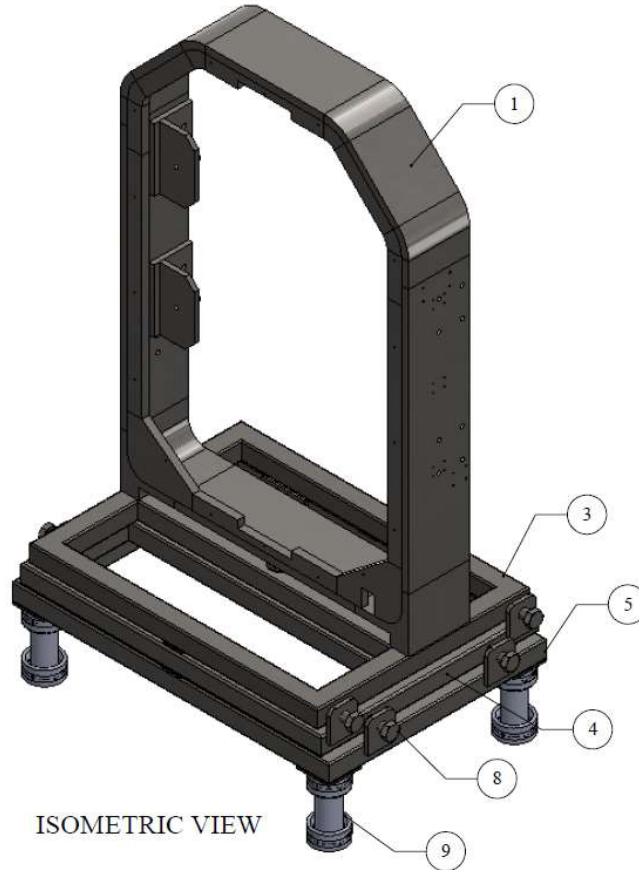

Fig 1: Beam Source Frame Structure

Appendix - 2

CERTIFICATE OF ASSURANCE of Wooden packages for Export

This is to certify that proper material(s) selection with adequate section/wall thickness and internal layout has been done to assure structural integrity of the packaging.

Packer

Appendix 3 – Visitor Permission Form

Institute for Plasma Research, Gandhinagar
Visitors Entry Permission Form (During Covid-19 restrictions)

1. Name of the Visitor* <i>* applicable to contractors as well</i>	
2. Arriving from place (state the exact location)	
3. Visitor's arrival & departure date and time	
4. Visitors organization name & address <i>If there are more than visitors/contract personnel for the same site-work contract please attach a list of their names and their individual travel history.</i>	
5. Purpose of visit	
6. Justification for inviting the visitor (State reasons of urgency)	
7. Travel history of persons for last 15 days (Domestic as well as international)	
8. Location within IPR campus where visitor will visit/work (Office, Labs etc.)	
9. Visitors have any health issue (yes /no) If yes, please specify the same	

Signature / Employee _____

Date : _____

Signature of Division Head _____

Approved by – Dean (Administration) _____

Appendix 4: Site Visit Clearance

Date:

Enquiry / Bid No.	
Date	
Item Description	
Due Date for Bid submission	

This is to confirm that

Mr.

of Messrs.

has / have visited the site at ITER-India Lab, Institute for Plasma Research on

				2	0		
--	--	--	--	---	---	--	--

to understand the scope of supply, work, technical specifications and get acquainted with the tender requirements related to above mentioned enquiry / tender.

(Bidder's signature)

Date:

Coordinator, ITER-India, IPR