



www.iter-india.org

## ITER-India, Institute for Plasma Research

Block A, Sangath SKYZ, Bhat- Motera Road, Koteswar, Ahmedabad 380005 Gujarat,India.

Ph.No. : +91-79-23269656/9575 FAX : +91-79-23269591 / 9501

Email : purchase@iter-india.org

### ENQUIRY - LOCAL

OFFICE COPY                      ENQUIRY NO                      : I-IEN21035  
Date                                      : 26/11/2021  
Due Date                                : 21/12/2021 by 5:00 PM (IST)

We invite your rate/s for the following item/s. The Instructions to bidders and Terms & Conditions are attached herewith.

#### Important Note :

1. Enquiry No., Date & Due Date should appear on the envelope otherwise your offer will be rejected.
2. Address quotation only to the Purchase officer.

Sr No.	Material Description	Quantity	Unit
1	Supply, Fabrication and installation of Aluminum section partition cabin for Diagnostic Lab (inside ITER-India Laboratory located in IPR campus ) as per attached technical specification	1	AU

#### Note :

- (1) Submit your quotation in hard copy (sealed envelope superscribing enquiry no and due date) AT THE ABOVE ADDRESS.
- (2) Any clarification on this enquiry may be sought from the Purchase Officer, ITER-India
- (3) Quote with complete technical details.
- (4) Quotation should invariably be submitted in the attached format (Quotation Format) ONLY else ITER-India may not consider your offer.
- (5) Refer to Annexure-A for Section -1 General Conditions of Contract including Scope of Work, Terms & Conditions , Rate analysis & Section-II for schedule of quantity and Proposed drawings of control cabin and Aluminum Section Partition. (total 09 pages).
- (6) The attached enquiry document Annexure-A (09 pages) to be returned duly filled in, signed & stamped with all the details along with the quotation. This will be considered as acceptance of bidder on Annexure-A.
- (7) Payment shall be made within 30 days through RTGS/NEFT from the date of final acceptance of ordered items/services at purchaser's site and on receipt of error free invoice and other necessary documents at our end. Payment shall be made on actual measure/verified quantities as installed.
- (8) TDS as per CGST Act: As per provisions of section No. 51 of the CGST Act 2017, TDS @2% (IGST 2% or CGST 1% and SGST 1%) will be deducted while making payment to the suppliers where total value of orders/contracts/work orders exceeds Rs. 2.5 lakhs, in the event of order in Indian Rupees. Necessary TDS Certificate will be issued to the supplier after TDS deduction. Income tax (TDS) at a prevailing rate on total order value as per Income Tax Act will be deducted from the invoice. Certificate of TDS will be issued by the Purchaser. TDS at the prevailing rate on total order value as per GST Act will be deducted from the Service Provider's Invoice(s). TDS certificate (Form GSTR-7A) will be issue to this effect.
- (9) Bidder under the category of Micro & Small Enterprise (MSE) for the quoted item/services shall attach MSE certificate. Purchase preference will be given to MSEs as defined in Public Procurement Policy for Micro and Small Enterprises (MSEs) Order, 2012 dated 23.03.2012 issued by Ministry of Micro, Small and Medium Enterprises and its subsequent Orders/Notifications issued by concerned Ministry. If the bidder wants to avail the Purchase preference, the bidder must be the manufacturer of the offered product in case of bid for supply of goods. Traders are excluded from the purview of Public Procurement Policy for Micro and Small Enterprises. In respect of bid for Services, the

bidder must be the Service provider of the offered Service. Relevant documentary evidence in this regard shall be uploaded along with the bid in respect of the offered product or service.

(10) GEM Availability Report Id: GEM/GARPTS/16112021/KKFTK5TCO41X dated 16.11.2021.

(11) Site to be visited and details to be entered as per Annexure I & to be submitted along with offer. Bidder can contact Mr.Mehul G Chodavadiya (M) 09328910232 before visiting the site.

(12) L1 bidder will be derived based on total amount (inclusive of applicable taxes & any other charges, if applicable).

(13) Any bidder from a country that shares a land border with India(i) , excluding countries as listed on the website of the Ministry of External Affairs(ii) , to which the Government of India has extended lines of credit or in which the Government of India is engaged in development projects (hereinafter called 'Restricted Countries') shall be eligible to bid in this tender only if Bidder is registered(iii) with the Registration Committee constituted by the Department for Promotion of Industry and Internal Trade (DPIIT). Bidders shall enclose the certificate in this regard as per Annexure II. (i) <https://mea.gov.in/india-and-neighbours.htm> (ii) <http://meadashboard.gov.in/indicators/92> (iii) <https://dipp.gov.in/sites/default/files/Revised-Application-Format-for-Registration-of-Bidders-15Oct2020.pdf>

(14) Bidder from such Restricted Countries" means: - a) An entity incorporated, established, or registered in such a country; or b) A subsidiary of an entity incorporated, established, or registered in such a country; or c) An entity substantially controlled through entities incorporated, established, or registered in such a country; or d) An entity whose beneficial owner is situated in such a country; or e) An Indian (or other) agent of such an entity; or f) A natural person who is a citizen of such a country; or g) A consortium/ joint venture where any member falls under any of the above.

(15) Documents to be Submitted along with offer- 1. Annexure-A- Duly Signed & Stamp, 2. Annexure-I Site visit report, 3. Annexure-II Self Declaration as per Sr. No. 13(Duly Signed & stamp), 4. MSME Proof.

Encl:- as above

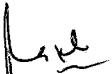
  
Rakhi Dharamdasani

Sr. Officer (Purchase & Stores)

ITER-India (IPR)

## TERMS AND CONDITIONS

1. The quotation and any order resulting from this enquiry shall be governed by our Conditions of Order and supplier quoting against this enquiry shall be deemed to have read and understood the same in to
2. Where counter terms and conditions have been offered by the Tenderer, the same shall not be deemed to have been accepted by ITER-India unless our specific written acceptance thereof is obtained.
3. Quotation: Your quotation superscripting our enquiry No., date, due date and brief description of item should be submitted to the Purchase Officer, ITER-India in sealed envelope on or before the due date. Late/ Delayed/incomplete quotations will not be considered. Envelopes received without Enquiry number, date, due date and brief description of item may be rejected. The quoted prices should be firm for a period of 90 days from due date for placing order. ITER-India is not bound to accept lowest rate/s. Bidder shall submit the price bid/offer on Bidder's letter head with official seal and sign on each page.
4. The bid documents shall be prepared in English language only
5. All pages of the bid documents shall be numbered. Each page of the bid document shall be stamped and initialized.
6. In the event of any date indicated above is a declared Holiday, the next working day with the same time limit shall become operative for the respective purpose mentioned herein
7. In case of deviation in payment terms including demand of advance other than specified in payment schedule and accepted by ITER-India, prevailing Prime Lending Rate (PLR) of SBI will be loaded for price comparison purpose
8. ITER-India and their authorized representatives may visit the Contractor/Sub-contractors if required as part of technical evaluation process
9. ITER-India reserves the right to place order on one or more parties.
10. Specifications: Material should be offered strictly conforming to our specifications/drawings, if any. Deviation, if any, should be clearly indicated by the supplier in their quotation. The Tenderer should also indicate the Make/Type number of the materials offered and catalogues, technical literature and samples, wherever necessary should accompany the quotation. Clarification/s on specifications/drawings should be obtained from Purchase Officer before submitting quotation.
11. Terms of Prices : Quotation should be submitted on door delivery basis, duly packed & insured without extra charge wherever possible. In the case of Indian suppliers, the material is to be delivered at our stores free of charge duly packed & insured.
12. Unit rate/s should be valid throughout the validity of Purchase Order for addition/deletion purposes. Break-up of price should be furnished. The quoted price should not be subject to price escalation for whatsoever reasons. The quoted price shall be firm, fixed and non-revisable during the validity/ extended validity of Purchase Order.
13. Prices are required to be quoted according to the units indicated in the tender form/Enquiry. When Quotations are given in terms of units other than those specified in the tender form, relationship between the two sets of units must be furnished.
14. Tender should be free from Correction and Erasures. Corrections, if any, must be attested. All amounts shall be indicated both in words as well as in figures. Where there is difference between amounts quoted in words and figures, amount quoted in words shall prevail. Unsigned quotations will summarily be rejected.
15. ITER-India shall be under no obligation to accept the lowest or any tender and reserves the right of acceptance of the whole or any part of the tender or portion of the quantity offered and the tenderers shall supply the same at the rates quoted. ITER-India also reserves the right to split the order at its sole discretion.
16. Octroi is not applicable at present.
17. Delivery Date/Period: Delivery period is essence of the Order. Supplier must indicate the firm delivery date by which the materials will be dispatched / delivered by them from the date of our order.
18. Delivery period shall be clearly indicated against each item separately.
19. Inspection: Materials on its arrival at ITER-India will be inspected by our Engineer/Stores In-Charge, and his decision in the matter will be final. However, where the items are required to be inspected at the Suppliers Premises, Supplier has to give advance notice to the Purchaser regarding readiness of the material to enable Purchase/Stores section to depute his representative for inspection.
20. Payment: Payment will be arranged for accepted materials only within 30 days from the date of acceptance of materials at ITER-India and receipt of error free bills in our accounts section, complete in all respects.
21. No correspondence will be entertained within 30 days from the date of receipt of material and bills, whichever is later.
22. Warranty: The Stores/Items offered should be guaranteed for a minimum period of twelve months from the date of acceptance, against defective materials, design, workmanship, operation or manufacture. For defects noticed and communicated during the Guarantee period, replacement/rectification should be arranged free of cost within a reasonable period of such notification. In case where our specifications call for a guarantee period more than 12 months specifically, then such a period shall apply.
23. The Contractor/Supplier shall at all times indemnify the purchaser against all claims which may be made in respect of the stores for infringement of any right protected by Patent, Registration of design or Trade Mark and shall take all risk of accidents or damage, which may cause failure of supply from whatever cause arising and the entire responsibility for sufficiency of all means used by him for the fulfillment of the Order.
24. Successful tenderer will have to furnish in the form a Bank Guarantee or in Indemnity Bond form as called for by the Purchaser towards adequate security for the materials/property provided/issued by the Purchaser as Free Issue Material for the due execution of the Order. Insurance for the Free Issue Material shall be arranged by the Supplier/Contractor at his risk and cost.
25. Non-compliance to tender specifications and/or tender scope and/or tender terms and conditions are liable for rejection. Decision of ITER-India in respect of non-compliance shall be final and binding on the bidders.
26. Canvassing in any form with regard to this tender will lead to rejection of the bid.
27. The Project Director, ITER-India reserves the right to accept or reject any quotations fully or partly or to cancel the enquiry without assigning any reasons.
28. This enquiry is not a commitment and the Purchaser reserves the right to reject or cancel any or all offers.
29. Jurisdiction: The Order shall be governed by the Laws of India for the time being in force. The Courts of Ahmedabad/Gandhinagar only shall have jurisdiction to deal with and decide any legal or dispute arising out of this Order.
30. Unsuccessful bidders will not be intimated about the results of the enquiry/tender.
31. Purchase will not be responsible for payment of any interest to the Supplier, in case of delay in releasing payment.
32. The price evaluation shall be carried out on Landed price.

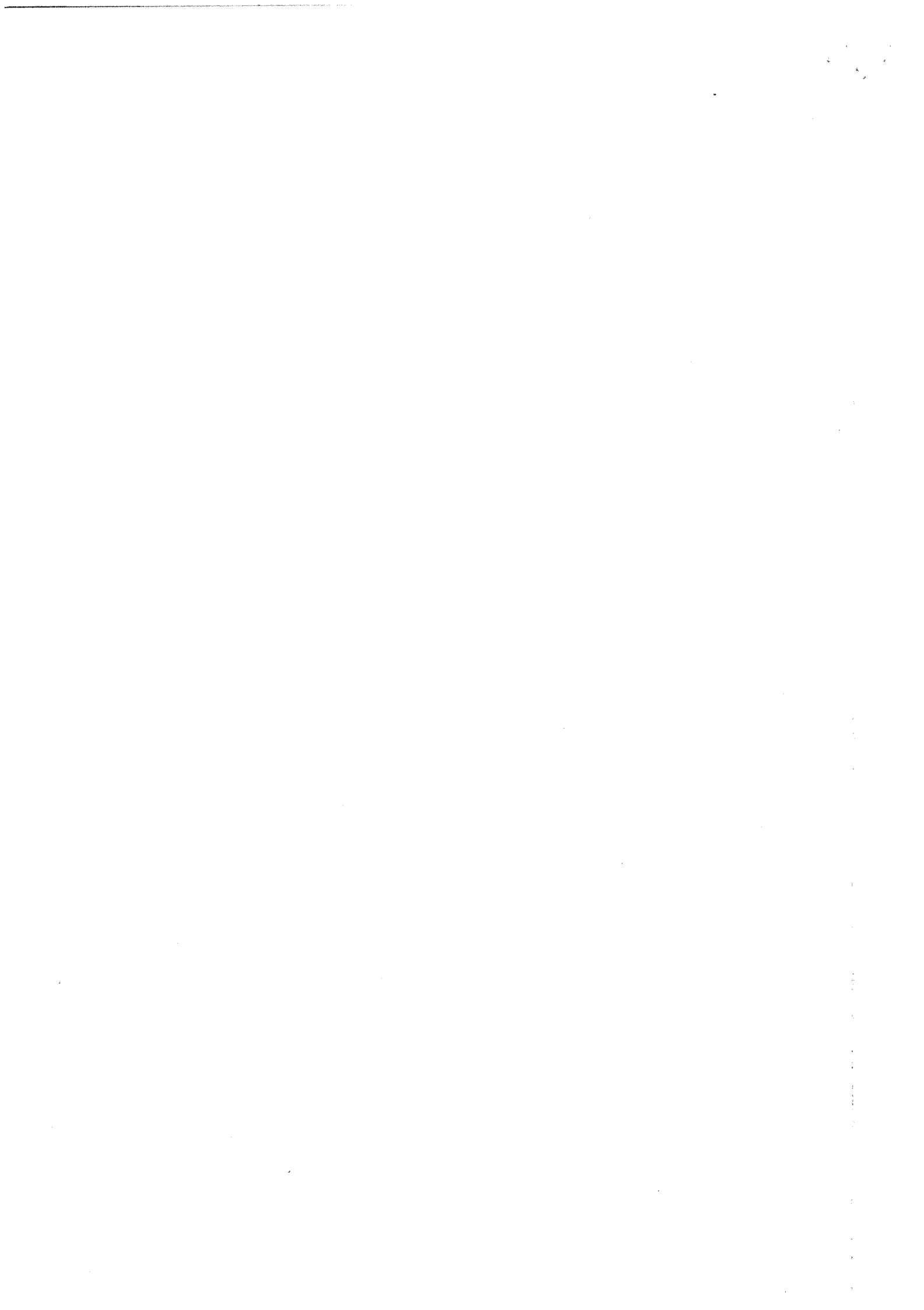

**CONSTRUCTION OF ALUMINIUM CONTROL CABIN AT ITER INDIA LAB BUILDING  
INSIDE IPR CAMPUS, BHAT, GANDHINAGAR**

Enq. No. I-IEN21035

Date: 23.11.2021

Due Date: 14.12.2021

**SECTION - I GENERAL CONDITION OF CONTRACT**

Name of contractor : \_\_\_\_\_

**1.1. SCOPE OF WORK**

The scope of work comprises of Construction of Aluminium Cabin at ITER-India Lab Building inside IPR campus located at Bhat, Gandhinagar (Gujarat). This work includes Aluminium partition, door, windows, glass, Compact sheet and other related civil works as per our requirement, design, specifications and estimated quantities mentioned in the contract/tender documents with the provision of all labour, materials, completion and maintenance so far as the necessity for providing the same is specified in or reasonably to be inferred from the contract. Maintenance thereof means rectification of defects observed during the defect's liability period of one year. The contractor has to carry out the work in such a manner that the Institute's routine work may not be disturbed. The contractor shall inspect the site before quoting the tender to see the lead, lift and wastage etc; for the said work. The bidder should collect the site visit certificate (As per Annexure-I) from the Engineer In charge and shall attach the same with their offer.

**1.2. THE RATES QUOTED BY CONTRACTOR ARE ALSO INCLUSIVE OF**

- I. Cost of labor, materials, tools, tackles etc.
- II. Use of scaffolding, curing, disposal of debris as directed.
- III. Cost for forming access to site with all temporary arrangement required for the work.
- IV. Cost of unloading, transporting, stacking and storing or supply of goods and materials for this work on the site and the places approved from time to time by Institute.
- V. Any other expenses required for fulfillment of Contractor's obligations as entered elsewhere in this contract.

**1.3. CONTRACTOR TERMS AND CONDITIONS**

The counter terms and conditions if offered by the contractor shall not be deemed to have been accepted unless it has specific written acceptance.

#### 1.4. RATES ANALYSIS

The contractor will be required to furnish analysis of the rates quoted by him for any item, if Institute so desires and notify the contractor to the effect. If so required by Institute he shall also be liable to furnish the original vouchers, bill, quotations etc.

#### 1.9. TIME PERIOD

The successful Tenderer shall commence the work within 5 working days from the date of award and the work shall be completed in all respect within 60 days from the date of receipt of work order excluding mobilization period of 5 days. In case the work is not commenced as stated above, the work order issued to Tenderer shall be liable for cancellation. In case the work is not completed as stated above, except for reasons beyond the control of contractor to the satisfaction of IPR, Institute may take following actions.

- a) In case the contractor stops the work the institute shall arrange to complete the same by other means and the amount of work completed will not be certified in any case.

#### 2.0 SUPERVISION BY THE CONTRACTOR

The contractor shall have sufficient supervisory manpower and organization so that one supervisor may be available on each job for day-to-day site work. The contractor shall have to arrange day-to-day planning and execution of each job. The contractor / his authorized representative shall report to the Engineer-in-charge for day to day planning and progress of the work.

#### 2.1 COMPLETION CERTIFICATE AND JOINT INSPECTION

The Contractor shall give notice of completion to Engineer-in-Charge immediately after completion of work and shall arrange for a joint inspection of work by his representatives and the ITER-India representatives. The contractor shall rectify defects pointed out during inspection within seven days. Thereafter final certificate to the effect that "the work has been completed to the satisfaction of ITER-India" shall be issued by the Engineer-in-charge and duly approved by Head, Infrastructure Section after the joint inspection and complying with the observations, if any made in the report. The work shall not be considered as complete until the contractor shall have removed from the premises on which the work shall be executed, all scaffolding, surplus materials, rubbish and cleaned off dirt from all wood works, doors, windows, wall, floor or other part of building where work is executed.

#### 2.2 STANDARD OF WORKMANSHIP AND MATERIAL USED FOR WORK

The contractor shall be required to execute the work in accordance with the standard of specifications for the workmanship and materials as per relevant Indian Standards and no deviation thereof shall be permitted without written permission from the Head, IIS. The entire work shall be free from poor and faulty workmanship and the contractor shall be liable to rectify all faults and defects if occurred and noticed within one year (Defect liability period) from the date of completion of the work

Detailed specifications wherever necessary should be obtained from the Engineer-in-Charge before execution of the work

### 3 LIABLE FOR DAMAGES

Contractor shall be responsible for making good at his cost to the satisfaction of the Institute, any loss of and any damage to all structures and properties belonging to the Institute or being not executed or procured or being procured by the Institute or of the other agencies within the premises of all the work of the Institute if such loss or damage is due to fault and/or the negligence or omission of the contractor, his employees, workmen or representatives or damage due to fire also. It is also worth to note that there may be live low voltage or high voltage electrical power cables, and water supply lines

lying at the area of work for which the contractor should take precautions (special care) at the time of execution of the work.

#### 4 DEFECTS LIABILITY PERIOD

The contractor shall be responsible for any damages except natural calamities such as earthquakes, heavy floods, etc. The contractor will be required to rectify any defects caused during this period of 1 year. The period of 1 year shall be reckoned from the date of final completion of work. He will not be paid any extra amount whatsoever required for rectifying those defects.

- 5 The Tenderer should sign all pages of the tender in token of acceptance of the terms and condition and return the same to us.
- 6 Before quoting the tender, Tenderer may visit the site of work, examine condition of the work and understand the work in consultation with engineer-in-charge.

#### 7 EXTRA ITEM WORKS

No alterations, amendments, omissions, additions or other variations of the work/ plant/ equipment under the contract (hereinafter referred to as "Variations") shall be made by the Contractor except as instructed in writing by Institute.

If there are items not included in scheduled of rates (hereinafter referred to as "Extra Items") Engineer-in-Charge shall have full power to ask contractor to carry out the same. Extra items should be carried out only after written permission of the INSTITUTE.

In case of the other items where no component is directly derivable from schedule of rates, reasonable rate for the item based on market rate of material and labour as ascertained by owner shall be taken as the basis allowing only 10% (ten percent) margin for contractor's profit, supervision and overheads. The Contractor will submit a rate analysis based on the market rates, original bills, vouchers, etc. in connection with determination of such rates. The opinion of the Institute as to current market rates of materials and the quantum of labour involved per unit of measurement will be final and binding on Contractor.

- 8 Quantities shown in the bill of quantities are approximate and may vary during the execution depending on the site conditions.
- 9 The contractor shall make his own arrangement for the security of his materials, plants and equipment's etc.
- 10 Institute reserves the right to adjust arithmetical or other errors in the tender in accordance with the following general rules. In the event of discrepancy between the rates quoted in words and figures, the description in words shall prevail. Similarly, in the event of an error in the amount column arising as a result of wrong extension, the unit or item rates shall be regarded as firm and the extensions amended accordingly.
- 11 The contractor shall note that this work has to be carried out inside Institute's campus, hence special care shall be taken at the time of execution of the work. The Contractor shall give strict instructions to his persons involved in the work, not to damage any equipment, fixtures or furniture lying inside the building. The contractor is fully responsible to clean the floor, paint, fixtures etc., after the completion of the work / at the time of execution of the work. He should also note that after completion of the work he shall dispose or stack the debris outside / inside of the campus as directed by Institute.
- 12 The tenderer should submit the entire document with all the pages of document duly signed.
- 13 If any clarification is required should be obtained before filling B.O.Q.

14 The Project Director, ITER-India reserves the right to accept or reject the tender in full or in part without assigning any reasons thereof.

**15 SAFETY CODE**

The contractor shall take all necessary precautions to ensure safety of labourers deployed for the said work and arrange to provide prompt medical assistance if required. Contractor should keep the fully equipped first aid box handy at the site.

The Institute is not in any case responsible for any type of accident during the execution of works and it will be the total responsibility of the contractor.

**16 WATER SUPPLY**

Temporary water for the said work shall be made available by the Institute at the points available at present **free of cost**. Contractor shall arrange to make a tapping, provide valves, provide and lay pipeline for distribution and use etc. complete at his own cost. Institute will in no way be responsible for delays in execution of work, if sufficient and continuous water is not available at site. It is the duty of contractor to arrange sufficient water for construction at his own cost, in case Institute is unable to provide required quantity of water for construction.

**17 ELECTRICAL POWER**

Institute may provide temporary power, at a single point **free of cost**. The cables, bulbs, electric fixtures etc. shall be provided by the contractor at his cost. Institute will in no way be responsible for any delays in execution of the work if sufficient and continuous power is not available at site. For any mishap due to his irregular maintenance and negligence, contractor shall be held responsible and liable.

**18 EQUIPMENT & MACHINERY ON WORK SITE**

- i. Sufficient scaffolding material as well as ropes, steel adjustable props having required spans of required strength, adjustable clamps, turn buckles, etc.
- ii. Any other tools/tackles/equipment necessary for the satisfactory and successful execution of the project, if necessary for the statutory requirements.

**19 CLEARANCE OF SITE ON COMPLETION**

On completion of the works, the contractor shall clear away and remove from the site, all surplus materials, rubbish and temporary works of every kind and leave the whole site, furniture, walls and works clean and in workman like condition to the satisfaction of Institute at his own cost. If the contractor fails to clear the site within 2 days after virtual completion/submission of final bill whichever is earlier, the Institute may get the site cleared at contractor's cost.

Contractor's signature and seal  
Date:



Annexure - I

**ITER-India, INSTITUTE FOR PLASMA RESEARCH**

Date:

(to be attached with the quotation as one of the conditions for meeting the eligibility criteria)

Enquiry No.	
Enquiry Date	
Enquiry Due Date	

This is to certify that

Mr.

of Messrs

has / have visited the Institute for Plasma Research on

				2	0	2	1
--	--	--	--	---	---	---	---

to understand the work and get acquainted themselves with details of Construction of Aluminum Control Cabin to enable them to quote against the enquiry for Supply, Fabrication and installation of Aluminum Section Partition.

(Engineer-In charge)  
ITER-India, Ahmedabad

**SECTION – II SCHEDULE OF QUANTITY**  
**CONSTRUCTION OF ALUMINIUM SECTION CABIN AT ITER INDIA LAB BUILDING AT**  
**BHAT GANDHINAGAR**

Sr. No.	Description	Unit	Quantity	Rate in RS	Amount in RS.
1	<p>Providing and fixing at all heights/ in all floors with all leads Anodized best extruded Aluminium sections for doors / partitions / ventilators/ sliding doors manufactured from JINAL / INDAL or equivalent make conforming to ISI, cut to length, joints mitered and corners grinded with joints water proof the outer frame and shutter frame stiffened with corner angle strips, fixing the frame with masonry and lintel, the frame work fixed with standard approved fastenings all generally as per details shown in drawings and specification with all the section pretreated for removal of any rust and prevention of further rust formation and finished with aluminum anodized coating including cost of pull and push plates and fixtures for hinged opening ( arrangements with steel bearings wherever necessary ), cost of providing and fixing aluminum decorative handles, door fittings like tower bolts, door stoppers etc. of approved quality ( Aluminium beading and glazing clips measured and paid under this item only )</p> <p>(Rate in words: )</p>	Kg	425.00		
2	<p>Providing and fixing 5 mm thick clear float glass in aluminum door or partitions panes including providing and fixing nylon/rubber/PVC lining desired shape, size and approved quality and fixing with aluminum glazing clips/aluminum bearings etc. complete as per the specification at all heights and directed by Engineers in Charge. (Supply cost of Aluminum clips / aluminum beading are measured in the item of aluminum sections for DOORS/WINDOWS/PARTITIONS etc.) the glass shall be of approved make like Asahi, Modi or equivalent.</p> <p>(Rate in words: )</p>	Sqm	30.00		
3	<p>Providing and fixing of 4-5 mm thick flat compact partition sheet in aluminum door or partition panes dully bonded with phenol formaldehyde of required shade and colour including cutting to required size and shape, size and approved quality, fixing with aluminum glazing clips or triangular beading (supply cost of aluminum clips/ aluminum beading are measured in item of aluminum sections for DOORS/WINDOWS/PARTITIONS etc.) including screws, other consumables etc. complete as per specification at all heights and directed by Engineer in Charge.</p> <p>(payment shall be made as per actual size fixed at site)</p> <p>(Rate in words: )</p>	Sqm	110.00		
4	<p>Supplying and fixing Chromium plated brass LOCK 4 levers 100mm 'LAXMI' or equivalent make, aluminum</p>	Nos.	1.00		

door lock with two keys, suitable either to single or double leaf shutter including making necessary recess in aluminum frame and fixing the lock with CP brass steel screws, tec. Complete as directed by Engineer-In-Charge.

---

(Rate in words: \_\_\_\_\_ )

---

---

***Total amount for this work***

(Total amount in words: \_\_\_\_\_ )

---

Contractor's signature and seal  
Date

**Proposed Drawings of Control Cabin and Aluminum Section Partition**  
**Control Cabin for Diagnostic Area-**

**Control Cabin at Diagnostic area**

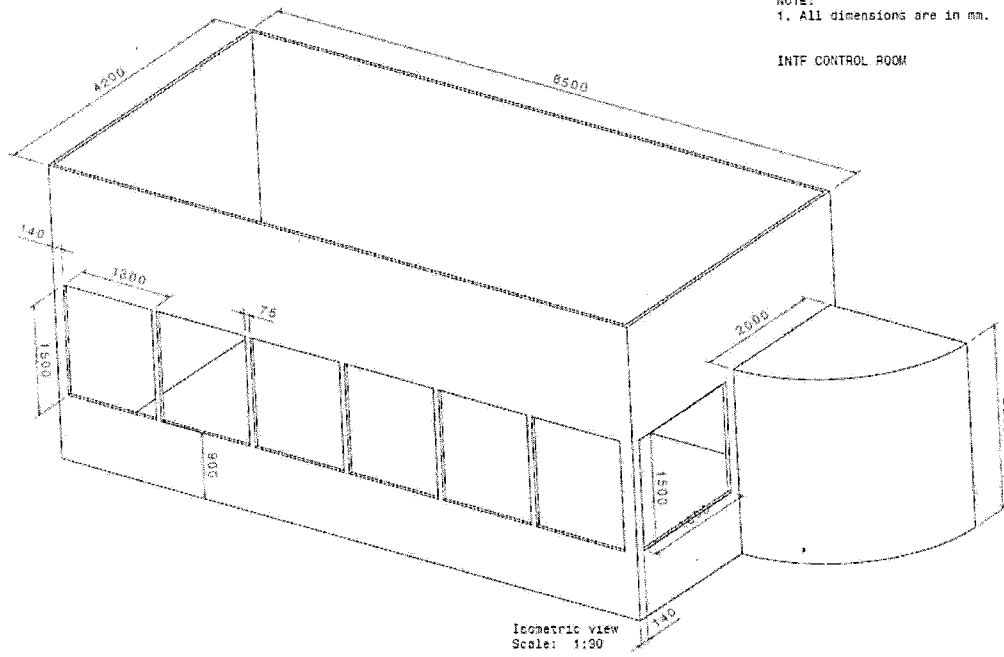

## B. Terms and Conditions

<b>Sr.No</b>	<b>Description</b>	<b>Bidder's Compliance</b>
1	Payment:ITER-India payment terms will apply (Refer Sr. No. 7 of Note)	Comply Yes/No (In case of No Please provide details)
2	Validity Period (Refer Sr.No. 3 Of Terms and Condition)	Comply Yes/No (In case of No Please provide details)
3	Completion period (Refer Sr. No. 1.9 of Annexure-A)	Comply Yes/No (In case of No Please provide details)
3	GST (To Specify as applicable)	
4	GST No.	
5	SAC Code	
6	Udhyog Aadhar No. & Category (Micro/Small/Medium Enterprise)	
7	Discount(if any)	
8	Remarks	

**Date:**

**Signature & Seal of the Contractor**

**Note:**

1. Refer Clause No. 1.2 of Section –I which is applicable for rates quoted.
2. L1 bidder will be derived based on total amount (inclusive of applicable taxes & any other charges, if applicable).
3. In case of any discrepancy found amount in figure V/s. amount in words, then amount in words shall prevail.





इटर-इण्डिया, प्लाज़्मा अनुसंधान संस्थान

ITER-India, Institute for Plasma Research

Block A, Sangath SKYZ, Bhat-Motera Road, Koteshwar, Ahmedabad-380  
005, Gujarat

**Enq. No.: I-IEN21035**

Annexure-II to Bid Form: Self Declaration (On company letter head) (Along with supporting documents, if any)

Tender No:

Tender Title:

Bidder's Name: \_\_\_\_\_ (Address and contact details)

Bidder's Offer No. \_\_\_\_\_ Date: \_\_\_\_\_

**Restrictions on procurement from Bidders from a country or countries, or class of countries under Rule 144(xi) of the General Financial Rules 2017.**

*We have read the clause regarding restrictions on procurement from a bidder of a country which shares a land border with India and on sub-contracting to contractors from such countries, and solemnly certify that we fulfil all requirements in this regard and are eligible to be considered. We certify that:*

- (a) *we are not from such a country or, if from such a country, we are registered with the Competent Authority (copy enclosed). and;*
- (b) *we shall not subcontract any work to a contractor from such countries unless such contractor is registered with the Competent Authority.*

Penalties for false or misleading declarations:

We hereby confirm that the particulars given above are factually correct and nothing is concealed and also undertake to advise any further changes to the above details. We understood that any wrong or misleading self-declaration by us would be violation of Code of integrity and would attract penalties as mentioned in this tender document, including debarment.

\_\_\_\_\_  
(Signature with date)

\_\_\_\_\_  
(Name and designation) Duly authorized to sign Bid for and on behalf of

\_\_\_\_\_  
(Name & address of the Bidder and Seal of Company)

