



www.iter-india.org

ITER-India, Institute for Plasma Research

Block A, Sangath SKYZ, Bhat- Motera Road, Koteswar, Ahmedabad 380005 Gujarat, India. Ph.No.

: +91-79-23269656/9575 FAX : +91-79-23269591 / 9501

Email : purchase@iter-india.org

ENQUIRY – FOREIGN (Reminder – 3)

OFFICE COPY ENQUIRY NO : I-IEF19004
Date : 23/08/2019
Due Date : 11/09/2019 by 1:00 PM (IST)

We invite your rate/s for the following item/s. The Instructions to bidders and Terms & Conditions are attached herewith.

Important Note :

1. Please Send your offer, ALONG WITH DESCRIPTIVE LITERATURE / CATALOGUE for the following items which we are interested to import directly against Foreign Trade Policy 2015-2020. Kindly go through the terms & conditions printed overleaf. Please ensure that your quotation reaches this office not later than above mentioned due date.
2. If Indian Agents are submitting the quotation on behalf of their Principal they should furnish the following documents without which their quotation is liable for rejection. a. Copy of Latest and Valid Authorization Certificate issued by their Principal. b. Copy of Proforma Invoice submitted by their Principal indicating the commission payable to the Indian agent, nature of after sale service to be rendered by the Indian agent. c. Copy of the Agency agreement with the foreign principal and the precise relationship between them and their mutual interest in the business. d. Indian agent who desire to quote directly on behalf of their foreign principals shall be enlisted with the Central Purchase Organisation (eg. DGS&D) under the compulsory enlistment scheme of the Ministry of Finance. Proof of enlistment to be submitted in the bid.
3. If Packing Materials are of any kind of Plant Origin, valid Phytosanitary Certificate issued by an Authorised Officer at the Country of Origin of the consignment in the format prescribed under the International Plant Protection Convention of the Food and Agricultural Organization shall be sent along with the shipping documents. This is a mandatory requirement under Law enacted by the Govt. Of India. Deviation from this may result in holding of the consignment at customs causing delays which will be the sole responsibility of supplier.
4. Customs Duty Exemption Certificate: ITER-India can provide Custom Duty Exemption Certificate (CDEC) under the notification no. 39/96 dated 23/07/1996 as amended by notification no. 5/2012 - custom dated 07/02/2012 (s. no.37) in order to avail such exemption indian party shall quote in foreign currency only on behalf of their foreign principal/supplier & purchaser shall place the order directly on foreign principal/supplier. All expenses, except customs duty, towards procurement of the imported materials should be borne by the Contractor.
5. ITER-India, IPR is entitled to avail concessional rate of GST @ 5% (2.5% CGST and 2.5% SGST) as per Central Goods and Service Tax (CGST) Notification No. 45/2017-Central Tax (Rate) dated 14th November, 2017, State Goods and Service Tax (SGST) Notification No. 45/2017 – State Tax (Rate) dated 15th November, 2017 and IGST @ 5% as per Notification No. 47/2017-Integrated Tax (Rate) dated 14th November, 2017 for supply of Goods. Therefore, please consider GST in your quotation accordingly. (Applicable for indian bidder)

Sr No.	Material Description	Quantity	Unit
1	Air insulated indoor Disconnecter Switch Unit Please refer attachment for detailed technical specifications	1	NOS

Note :

- (1) Quotation should invariably be submitted in hard copy as per attached "Format for Submission of Quotation" ONLY else ITER-India may not consider your offer.
- (2) Technical Specifications for the item are attached herewith (2 pages). Vendor Compliance of Technical sheet needs to be filled, signed & Stamped & to be sent along with the offer. This will be considered as your acceptance.
- (3) In respect of Foreign Bidders: The price/s quoted should be on FOB (any international airport in supplier's country) basis as per Incoterms 2010. The price/s quoted should be inclusive of all applicable taxes, levies, duties

applicable outside India. The bidder shall also indicate the DAP (ITER-India) charges in terms of % of FOB Price. DAP charges shall be included with the quoted FOB price for evaluation purpose by the Purchaser.

- (4) Submit your quotation AT THE ABOVE ADDRESS
- (5) Any clarification on this enquiry may be sought from the Purchase Officer, ITER-India.
- (6) In a tender, either the Indian agent on behalf of the Principal/OEM or Principal/OEM itself can bid but both cannot bid simultaneously for the same item/product in the same enquiry.
- (7) In respect of Indigenous bidders: The price/s quoted should be on Door Delivery and freight paid basis inclusive of cost of packing & insurance.
- (8) Exchange rate as on the due date of bid submission shall be taken for price evaluation. Prices shall be evaluated on landed cost (i.e. including all the applicable taxes and charges) basis.
- (9) Payment shall be made within 30 days from the date of final acceptance of ordered items by the purchaser at his site. Payment shall be made through wire transfer (for foreign bidders) and through NEFT (for Indian bidders).
- (10) Applicable IGST for import items is 5% under notification no. 47/2017, which shall be loaded during evaluation of offer from foreign bidder.
- (11) Indian bidder shall quote the rate exclusive of all applicable taxes & duties. Foreign bidder shall quote rates inclusive of all applicable taxes & duties arising outside India.
- (12) Indian agent shall bid on behalf of one Principal/OEM only.
- (13) Authorised dealer/ Distributor certificate to be submitted with the offer, failing which, offer may not be considered for evaluation.

Encl:- as above

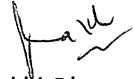

Rakhi Dharamdasani
OFFICER-I (PURCHASE & STORES)
ITER-India (IPR)

INSTRUCTION TO TENDERERS

1. The Proforma Invoice should contain the following information:
2. The earliest delivery period and country of goods / equipment and Country of shipment should be mentioned.
3. Your banker's name and address should be mentioned. All bank charges outside India to be borne by the supplier.
4. The tenderer should submit quotation to the Purchase Officer in duplicate in sealed envelope superscribing the Tender No., date and due date of opening. Quotation should be submitted in the form of a Proforma Invoice and should complete in all respects with technical specifications. Note for Indian Agent: Bidder should submit quotation on behalf of only one foreign supplier.
5. Agency commission, if any, payable to the Indian Agent from the FOB/FCA value should be clearly indicated in terms of percentage of the same. Also the address of the accredited Indian Agents should be furnished so that the agency commission can be paid in Indian Rupees directly to them at the exchange rate (T.T. buying) prevailing on the date of purchase order.
6. The approximate net and gross weight and dimension of packages / cases may be indicated in your offer.
7. Recommended spares for satisfactory operation for a minimum period of 5 years (wherever applicable) may be mentioned.
8. Details of any technical service, if required for erection, assembly, commissioning and demonstration should be mentioned clearly.
9. The prices quoted should be inclusive of all taxes, levies, duties arising in the tenderer's country.
10. The offers should be valid for a minimum period of 120 days from due date of opening of the tender. If asked for by the Purchaser, the tenderer shall extend the validity of his quotation.
11. Late tenders will not be considered. Quotations by cable/fax must be followed by detailed offers by mail/through courier so as to reach us before the due date.
12. The Purchaser reserves the right to accept the lowest or any tender in part or full without assigning any reasons. Purchaser also reserves the right to split the order at its sole discretion.
13. The details of Import License will be furnished in the Purchase Order.
14. Instruction / Operation manual containing all assembly details including wire diagrams should be sent wherever necessary in duplicate. All documents/correspondence should be in English Language only.
15. This enquiry is not a commitment and the Purchaser reserves the right to reject or cancel any or all offers.
16. Bidder should indicate clearly in his quotation whether he needs Export License for supply of the offered items. Furnish relevant document/format to be submitted by the purchaser, if Export License is involved.
17. Security Deposit (if applicable): The Supplier shall at the option of the purchaser, furnish an interest free Security Deposit for 10% of the purchase order value within 15 days from the date of Letter of Intent/Purchase order by way of Bank Guarantee for an equivalent amount.
18. Liquidated Damages (if applicable): The successful Vendor/Bidder should pay liquidated damages @ ½% (half percent) of the total order value for the delay of each week in the schedule of completion of supply/work envisaged in the Purchase Order subject to a maximum of 5% (five percent) of the total order value.
19. Advance payment, if any, will be made as per the Reserve Bank of India's stipulations and on receipt of Bank Guarantee from the Supplier from a Bank acceptable to Purchaser/Purchaser's Banker.

TERMS AND CONDITIONS

1. It is expressly agreed that the acceptance of the stores contracted for is subject to final approval in writing by the purchaser whose decision shall be final.
2. If all or any of the stores are not of the quality specified, they may be rejected and suppliers should either replace or refund the money at the discretion of the purchaser.
3. Part shipment is not allowed unless specifically agreed by the purchaser.
4. As far as possible, stores should be dispatched by Indian flag vessels/Air India or through any Agency nominated by the purchaser.
5. Adequate packing to prevent damage in transit should be provided keeping in view the nature of item and the mode of transport.
6. ITER-India being an Autonomous Institute of Government of India, preference will be given for payment by Sight Draft. However, you may indicate your payment terms.
7. The Supplier will be held responsible for any demurrage/Wharfage paid due to non-receipt of document in time. Non-negotiable copies of dispatch documents should be sent by Email (scan copy) /Air Mail/Courier immediately after shipment.
8. Insurance wherever necessary will have to be arranged by the supplier on Warehouse to warehouse basis.
9. Inspection/Test certificate should be provided for the goods after testing it thoroughly at your works, if any testing agency is considered necessary, it shall be arranged by the Supplier.
10. The stores contracted should be guaranteed for a minimum period of 12 months from the date of acceptance against defective materials, design, workmanship, operation or manufacture. For defects noticed during the guarantee period, replacement/rectification should be arranged free of cost within a reasonable period of such notification. However, permits for re-export from and re-import into the purchaser's country, if required shall be provided.
11. To fulfill the above guarantee condition, the Supplier shall at the option of the purchaser, furnish a Performance Bank Guarantee (as prescribed by the purchaser) from a Bank approved by the purchaser for an amount equivalent to 10% of the value of the Purchase Order valid till 14 months (i.e. covering guarantee/warranty period) from the date of acceptance of items by the Purchaser. On the satisfactory performance and completion of the Purchase Order, in all respects, the bank guarantee will be returned to the Supplier without any interest.
12. Where erection or assembly or commissioning is a part of the Purchase Order, it should be done immediately on notification. The Supplier shall be responsible for any loss/damages sustained due to delay in fulfilling this responsibility.
13. Supplier is deemed to have warranted and indemnified the Purchaser against any Claim/dispute whatsoever on patent, trade mark etc.
14. All disputes or differences whatsoever arising between the parties out of or relating to the construction, meaning and operations or effect of Purchase Order arising out of this tender or the breach thereof shall be settled by arbitration in accordance with the Arbitration Rules of India and the award made in pursuance thereof shall be binding on the parties.
15. For items having shelf life, those with maximum shelf life should be supplied, if order is placed.
16. These terms and conditions are subject to Ahmedabad, India jurisdiction only.
17. DO NOT SEND CONSIGNMENT/PARCEL THROUGH COURIER MODE.
18. Adequate packing to prevent damage in transit should be provided keeping in view the nature of item and the mode of transport.
19. If all or any of the stores are not of the quality specified, they may be rejected and suppliers should either replace or refund the money at the discretion of the purchaser.

FORMAT FOR SUBMISSION OF QUOTATION

Enquiry No. : I-IEF19004
Name Of Party : OFFICE COPY
Quotation No. & Date :
Due on : 11/09/2019 by 1:00 PM (IST)

Sr No.	Material Description	Qty	Unit	Rate	Total
1	Air insulated indoor Disconnecter Switch Unit Please refer attachment for detailed technical specifications	1	NOS		
				Grand Total	

COMMERCIAL TERMS & CONDITIONS *

Sr.No	Description	Bidder's Compliance
1	Delivery period (To Specify)	
2	Payment (Sr. No. 12 Note of Enquiry)	Comply Yes/No (In case of No Please mention details)
3	Warranty (12 Months from the date of acceptance)	Comply Yes/No (In case of No Please mention details)
4	Validity period (90 days from the date of opening of tender)	Comply Yes/No (In case of No Please mention details)
5	Discount (if any)	
6	Agency Commission (if payable to Indian Agent)	
7	Indian Agents: Those who are submitting offer on behalf of their principal must attach valid authorization letter issued by their Principal invariably & other documents as per Sr. No. 2 of Important Note	Submitted – Yes/No
8	Quoted INCOTERMS 2010 : Place of Delivery	
9	Packing & Forwarding charges (If not included in rate quoted above)	
10	Inland Freight/Insurance for DAP ITER-India, Gandhinagar	
11	Documentation Charges/Bank Charges (If not included in rate quoted above)	
12	GST (5% against concessional certificate) (As per sr. No. 5 of Important Note)	Comply Yes/No (In case of No Please mention details)
13	GST not Included in Quoted Rate (For Indian Bidder)	Comply Yes/No (In case of No Please mention details)
14	Mention GST No.	
15	HSN Code	
16	Other Charges (if any) (To Specify)	
17	Remarks (If Any)	

* Fill in the applicable details

Place:

Authorised Signatory:

Date:

Company Seal

Technical specification for Air insulated indoor Disconnecter Switch Unit

S.No	Parameter	Specification	Vendor Compliance
1.	Type	Air insulated indoor dis-connector with vertical-break contacts, non-enclosed type	
2.	Compliance Standard	IEC 62271-102	
3.	Rated voltage (Ur)	24 kV AC	
4.	Continuous current rating	400 A or nearest standard rating	
5.	Rated frequency	50Hz	
6.	Number of pole	2 pole	
7.	Rated Insulation level		
	<i>Dielectric withstand voltage 1 min/50Hz</i>	50kV – common value 60kV – across isolating distance	
8.	Rated short time withstand current	25kA, 1 sec	
9.	Mounting position	Horizontal	
10.	Mechanical endurance class	25000 Cycle (Class M2)	
11.	Detail of Insulator & Fire behaviour	Cast epoxy resin, Fire class UL94-V1	
12.	Type of Operating Mechanism	1. Motorized Operation 2. Manual Operation (Additional provision to be provided with manual crank handle to operate dis-connector switch in event of motor drive is not healthy)	
13.	Fixed contact material	Cast copper	
14.	Control Box	1. Dis-connector to be provided with a control box to operate the dis-connector (open and close). 2. Control box shall be loose having cable length of at least 10meters, to be mounted at separate location 3. Rated supply voltage for auxiliary and control circuit - 230V,50Hz AC Single phase, two-wire system OR - 400V,50Hz AC Three phase, three-wire system 4. Control box assembly shall comply to relevant IEC / National standard	
15.	Auxiliary switch / Micro switch to signal the disconnector position	2 NC + 2 NO (potential free contacts dedicated for user)	

16.	Configuration for disconnectors	Disconnector with earth bar, moving contacts connected to earth bar in open position <u>Refer Suggested Drawing for Details</u>	
-----	---------------------------------	--	--

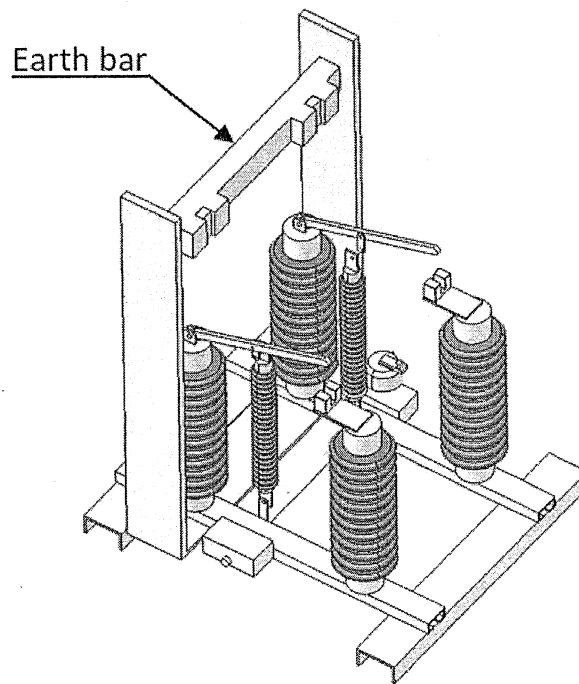

Figure 1 Suggested scheme for Dis-connector configuration

Note;

- A. Bidder has to submit general arrangement drawings for dis-connector unit along with the offer.
- B. In case of order, bidder has to provide routine test report along with supply
- C. Bidder must submit specification for the offered product, duly filled in table attached
- D. Please attach the datasheet/catalogue/specification at the time of quotation.
- E. Packaging, Loading and Transportation are under the scope of supplier.
- F. Items shall be delivered at:

**ECRH laboratory,
ITER-India Laboratory Building,
Institute for Plasma Research,
Bhat, Gandhinagar-382428
Gujarat, India.**